

Attachment for multispindle automatics used to make multiple radial drillings on rotating pieces.

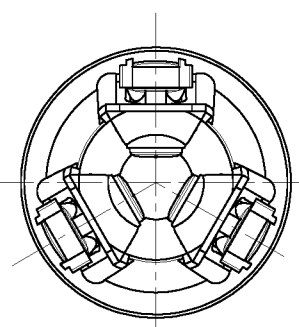
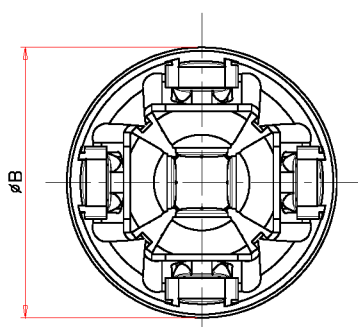
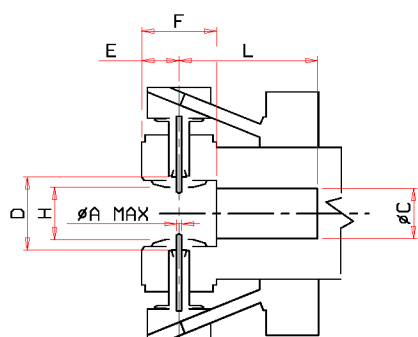
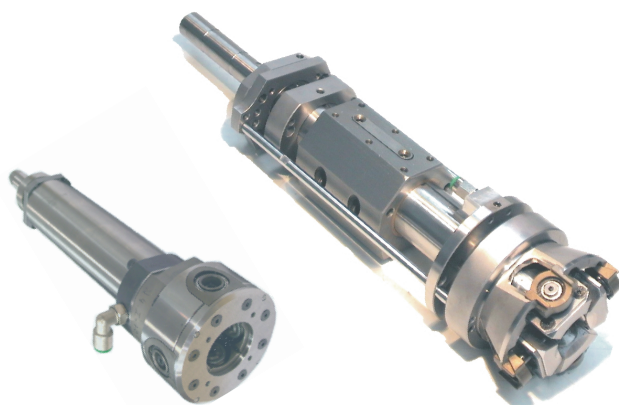

Size	Gr.0	Gr.1	Gr.2
Max speed [min ⁻¹]	3500	3000	2500
Max drilling stroke	5	6.8	9
Drive ratio tool/spindle	3.2:1	2:1	2.23:1
Ratio axial stroke/radial stroke	1.7:1	2.5:1	2.5:1
Max collet capacity ϕA	2.5	3	5.5
External head diameter ϕB	81.5 (86.5)	111 (119)	129 (135)
Internal diameter ϕC	13.5	22	29
D	27	32	43.4
E	18	16.5	18
F	30.5	33	41
Max external part H	27	23	31.5
L	20	61	80
Drill	Left hand cut	Left hand cut	Left hand cut